

Ultra Plus (LR8D425)

AAAA

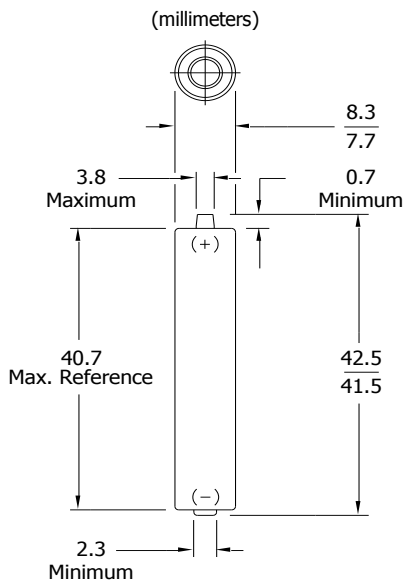

Industry Standard Dimensions



Classification:	Alkaline
Chemical System:	Zinc-Manganese Dioxide (Zn/MnO ₂) No added mercury or cadmium
Designation:	ANSI-25A, IEC-LR8D425, LR61
Nominal Voltage:	1.5 volts
Nominal IR:	150 to 300 milliohms (fresh)
Operating Temp:	-18°C to 55°C
Typical Weight:	6.5 grams
Typical Volume:	2.2 cubic centimeters
Jacket:	Plastic Label
Shelf Life:	5 years at 21°C
Terminal:	Flat Contact

Milliamp-Hours Capacity

Continuous discharge to 4.8 volts at 21°C

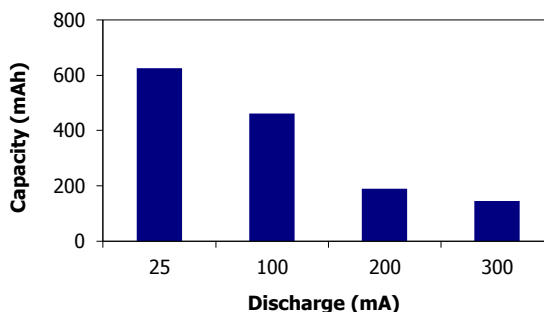

Industry Standard Testing (21°C):

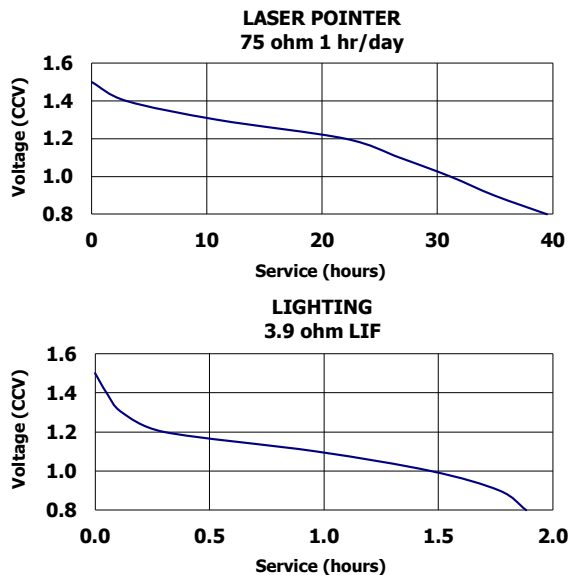

Battery Selection Indicator

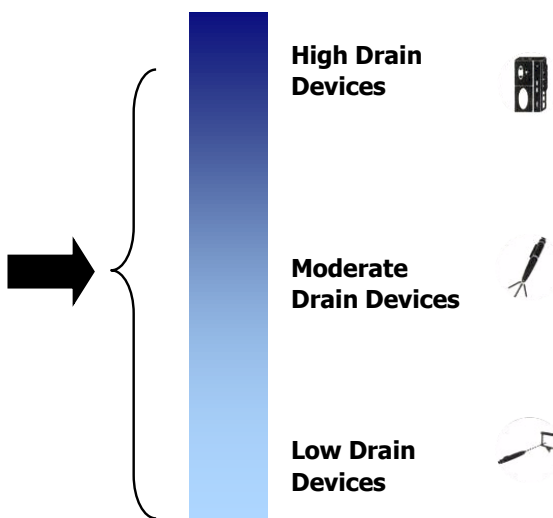

Important Notice

This datasheet contains typical information specific to products manufactured at the time of its publication.
©Energizer Holdings, Inc. - Contents herein do not constitute a warranty.